

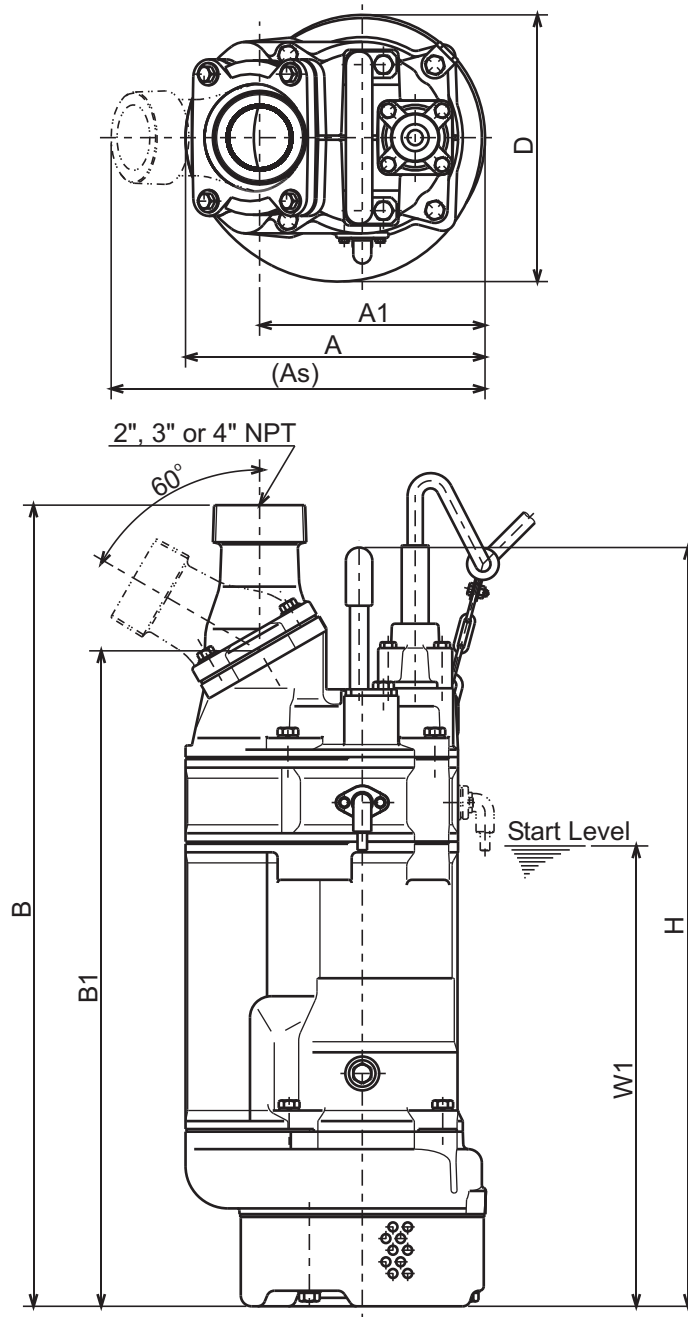

KTZE - SERIES
DEWATERING PUMPS (AUTO TYPE)

DIMENSIONS

KTZE23.7-61
KTZE33.7-61
KTZE43.7-61



DIMENSIONS:USCS (Inch)

Model	HP	NOM. SIZE	Pump & Motor							Start W1	Wt. (lbs.)
			A	As	A1	B	B1	D	H		
KTZE23.7-61	5	2"	11 1/8	13 5/16	8 3/8	29 7/16	24 3/8	9 15/16	28 1/4	17 1/8	163
KTZE33.7-61	5	3"	11 1/8	13 7/8	8 3/8	29 13/16	24 3/8	9 15/16	28 1/4	17 1/8	163
KTZE43.7-61	5	4"	11 1/8	14 1/2	8 3/8	30 3/16	24 3/8	9 15/16	28 1/4	17 1/8	163

DIMENSIONS:METRIC (mm)

Model	kW	NOM. SIZE	Pump & Motor							Start W1	Wt. (kg)
			A	As	A1	B	B1	D	H		
KTZE23.7-61	3.7	50	283	337	213	747	619	252	717	435	74
KTZE33.7-61	3.7	80	283	353	213	757	619	252	717	435	74
KTZE43.7-61	3.7	100	283	368	213	767	619	252	717	435	74



KTZE - SERIES DEWATERING PUMPS (AUTO TYPE)

PERFORMANCE CURVE

MODEL		BORE	HP	KW	RPM	SOLIDS DIA	LIQUID	SG.	VISCOSITY	TEMP.
KTZE33.7-61		3"/80mm	5	3.7	3410	0.334"/8.5mm	Water	1.0	1.123 cSt.	60°F
PUMP TYPE		PHASE	VOLTAGE		AMPERAGE		HZ	STARTING METHOD		INS. CLASS
Dewatering Pump		3	208-220/460/575		15.0-13.8 / 6.8 / 5.3		60	Direct On Line		F
CURVE No.	DATE	PHASE	VOLTAGE	AMPERAGE	HZ	STARTING METHOD	INS. CLASS			
-	-	-	-	-	-	-	-			

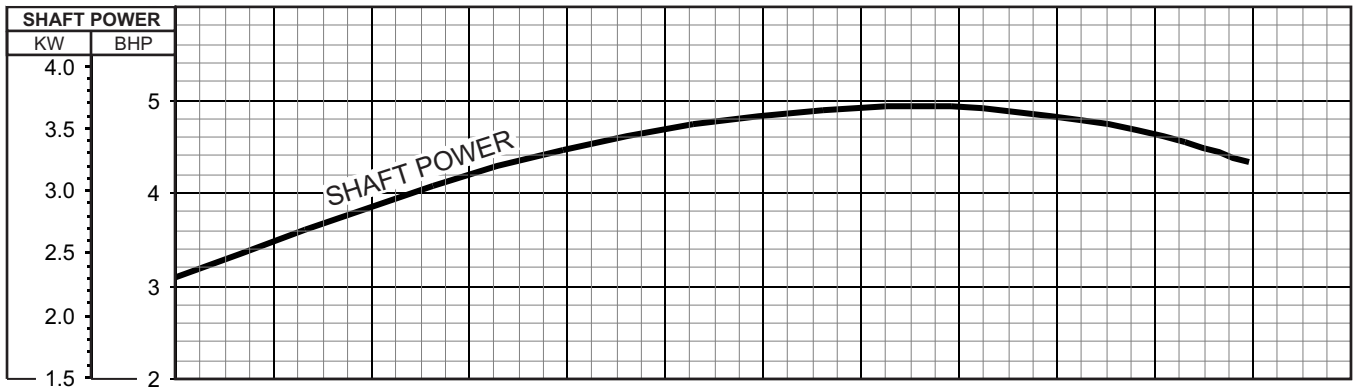
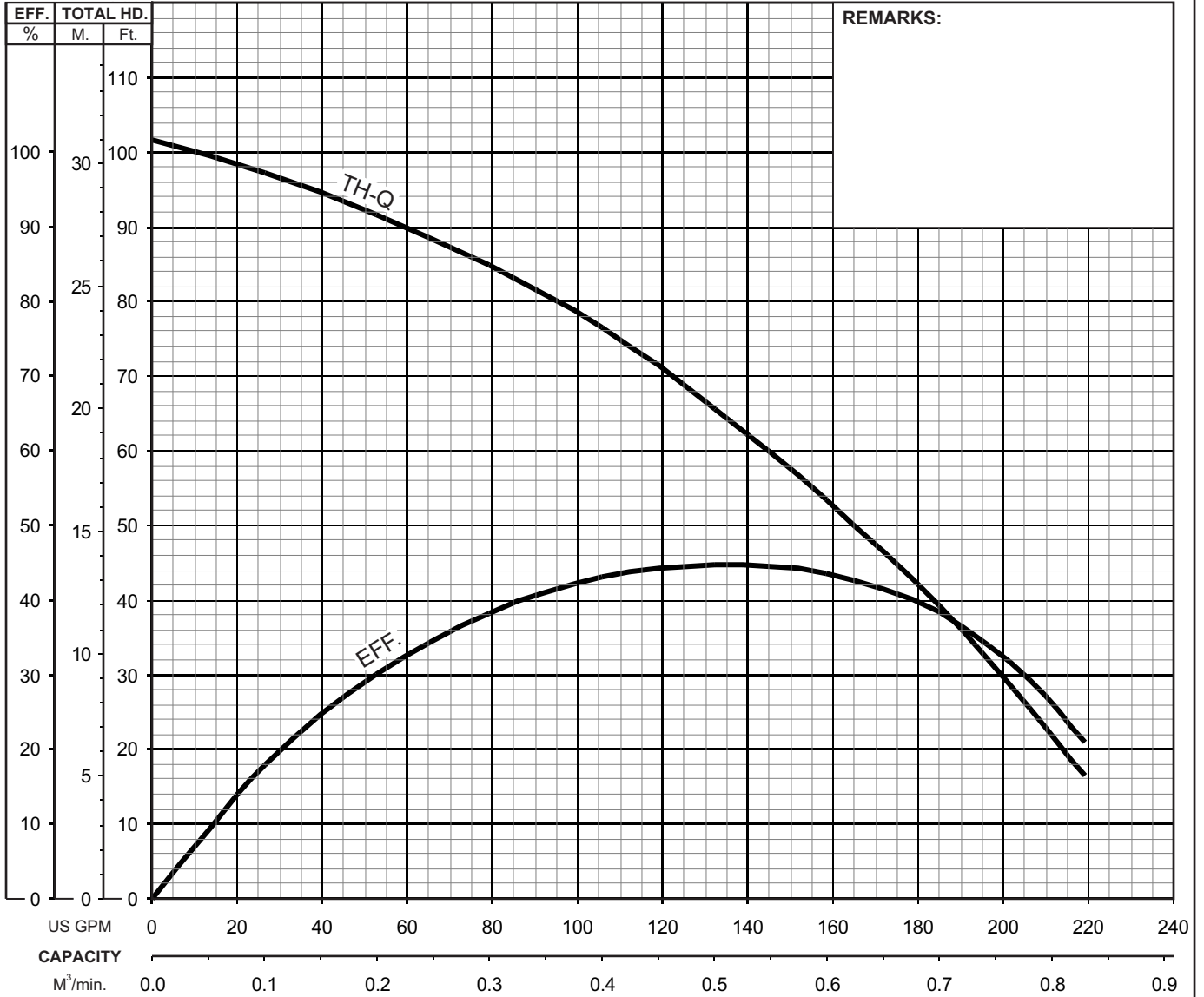



KTZE - SERIES
DEWATERING PUMPS (AUTO TYPE)

SECTIONAL VIEW

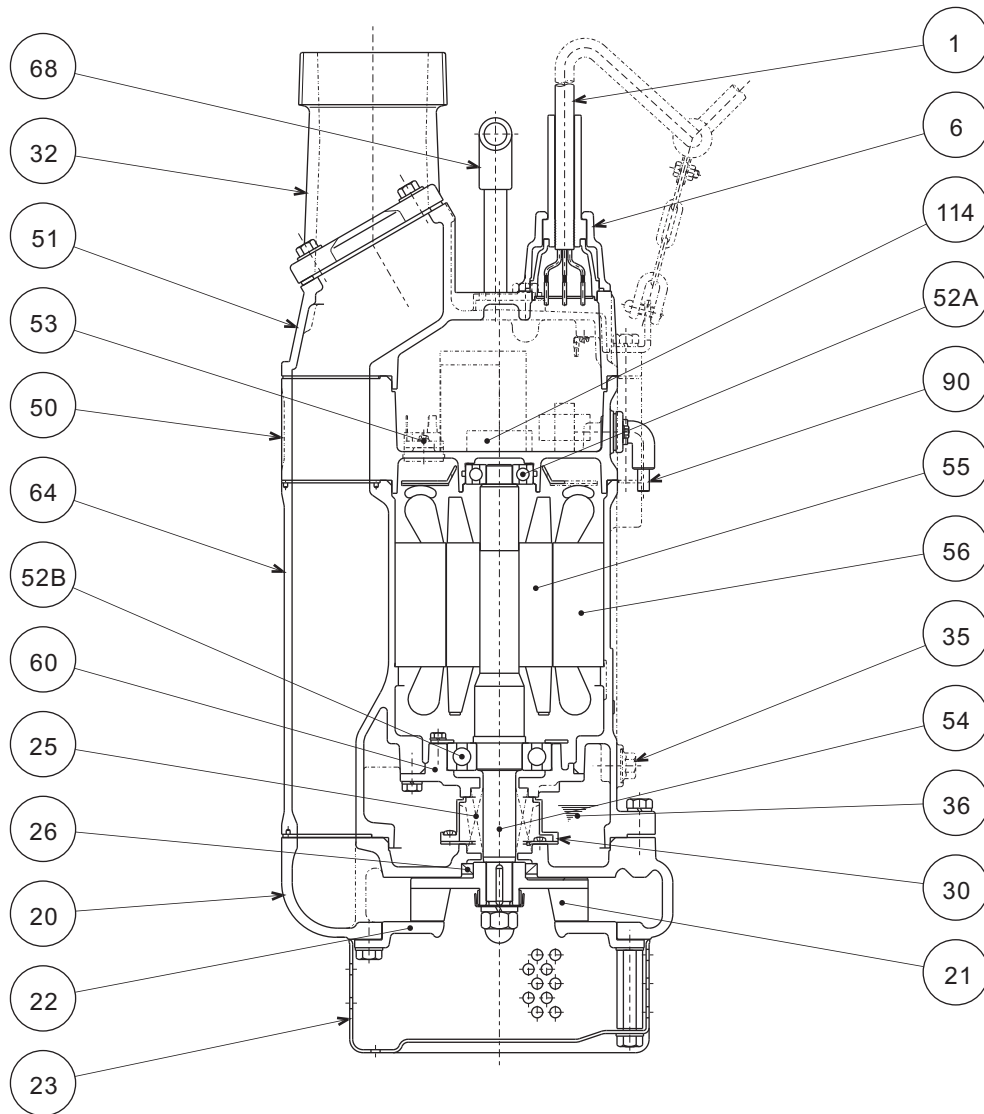

KTZE23.7-61
KTZE33.7-61
KTZE43.7-61

ITEM#	DESCRIPTION	MAIN MATERIAL / NOTE	RELATED ASTM, AISI CODE	RELATED EN CODE	Q'TY
1	Power Cable	Chloroprene Sheath AWG14/4-50ft			1
6	Stuffing Box	Cast Iron	A48M Class30B	EN 1561 GJL-200	1
20	Pump Casing	Cast Iron	A48M Class30B	EN 1561 GJL-200	1
21	Impeller	High Chrome Cast Iron	A532 Class III Type A	DIN 1695 G-X260Cr27	1
22	Suction Cover	Ductile Cast Iron	A536 80-55-06	EN 1563 GJS-500-7	1
23	Suction Strainer	Steel (Cold Rolled)	A109/A1008	EN 10130	1
25	Mechanical Seal	Silicon Carbide / H-25T			1
26	Oil Seal	Nitrile Butadiene Rubber / TC-40588			1
30	Oil Lifter	PBT Resin			1
32	Discharge Connection	Cast Iron / NPT 2", 3" or 4"	A48M Class30B	EN 1561 GJL-200	1
35	Oil Plug	Stainless Steel	S 30400	1.4301	1
36	Lubricant	Turbine Oil ISO VG32 or SAE10W-20			1
50	Motor Bracket	Cast Iron	A48M Class30B	EN 1561 GJL-200	1
51	Motor Head Cover	Cast Iron	A48M Class30B	EN 1561 GJL-200	1
52A	Upper Bearing	#6304ZZC3			1
52B	Lower Bearing	#6307ZZC3			1
53	Motor Protector				1
54	Shaft	Stainless Steel	S 42000	1.4028	1
55	Rotor				1
56	Stator				1
60	Bearing Housing	Cast Iron	A48M Class25B	EN 1561 GJL-150	1
64	Motor Housing	Cast Iron	A48M Class25B	EN 1561 GJL-150	1
68	Handle	Carbon Steel Pipe + NBR Rubber	A53 Type F	DIN 1615 St33	1
90	Level Sensor (Electrode)	Stainless Steel + Chloroprene Rubber	S 30400	1.4301	1
114	Relay Unit				1

PARTS LIST		AUTOMATIC DEWATERING PUMP			6/7/2018	
ITEM	PART No.	DESCRIPTION	QTY	SIZE	MATERIAL	NOTES
1	140-074-15	Hex.Bolt	2	M10x20	SUS304	
2	068-000-36	Handle	1	KTZ23.7/45.5	SGP+SS	
3	010-124-15	Cable Clip Rubber	1	No.3	NBR	
4	010-120-18	Cable Clip	1	No.2-1	SPC	
5	140-032-37	Hex.Bolt	1	M6x15	SWRM	
6	141-004-59	Hex.Nut	1	M6	SWRM	
7	095-131-18	Chain	1	4mm(3L)	SS	
8	011-110-11	Shackle	1	6mm(M8,SC)	SS	
9	001-840-32	Cabtyre Cable Set (50') 60Hz(USA)	1	2PNCTF4Cx2mm2	KTZ	
10	140-060-18	Hex.Bolt	4	M8x50	SUS304	
11	006-167-17	Stuffing Box	1	No.1-3	FC	included in ITEM# 9 Cable Ass'y
12	122-121-12	Packing	1	G-50(49.4xd3.1)	NBR	*
13	004-167-11	Cable Bush	1	No.1	CR	included in ITEM# 9 Cable Ass'y
14	008-156-19	Mould Cover	1	No.1-3	ADC	included in ITEM# 9 Cable Ass'y
15	009-126-13	Terminal	4	1.25mm2/2mm2	Nylon	included in ITEM# 9 Cable Ass'y
16	002-135-14	Heat Shrink Tube (Sold per meter)	m	A(d15x0.3t)	(Vm)	
17	140-000-87	Hex.Bolt	4	M10x35(B=14)	SUS304	
18	142-128-24	Plain Washer	4	M10	SPC	
19	032-000-92	Hose Coupling	1	KTZ33.7-63(NPT-3,Angle)	FC	
20	121-001-48	Packing	1	KTZ-3.7/7.5(Angle)	NBR	*
21	140-000-88	Hex.Bolt	4	M10x120(B=14)	SUS304	
22	142-164-19	Spring Washer	4	M10	SUS304	
23	070-117-11	L-Shape Fitting	1	40x25x4.5t d13Hole	SPC	
24	051-000-50	Motor Head Cover	1		FC	
25	122-276-13	O-Ring	1	160xd3.1	NBR	*
26	009-293-12	Earth Terminal	1Set	2mm2x180L		
27	143-085-21	Pan Screw (w/Spring Washer)	1	M4x6	SWRM	
28	009-000-33	Intermediate Lead Wire	1Set	2mm2x200L (Red,TMEV2-4White)		
29	009-000-35	Intermediate Lead Wire 208/220V-60Hz(USA)	1Set	2mm2x190L (Black,TMEV2-4White)		
	009-001-34	Intermediate Lead Wire 460V-60Hz(USA)	1Set	2mm2x190L (Black,TMEV2-3.5White)		
30	009-000-34	Intermediate Lead Wire	1Set	2mm2x150L(White)		
31	009-275-18	Compression type Terminal	1	TGNB-5.5(Insulated)	CU	
32	009-285-11	Solderless Terminal 208/220V-60Hz(USA)	2	TMEV-2-4	CU	
	009-001-37	Solderless Terminal 460V-60Hz(USA)	2	TMEV2-3.5	CU	
33	009-001-32	Intermediate Lead Wire	1Set	AWG22x130L (Orange/Yellow)		
34	114-168-16	Electromagnetic Contactor 208/220V-60Hz(USA)	1	SD-M19/SD-Q19		
	114-000-86	Electromagnetic Contactor 460V-60Hz(USA)	1	SD-Q11		
35	143-182-16	Pan Screw (w/Spring Washer) 208/220V-60Hz(USA)	2	M4x16	SWRM	
	143-000-61	Pan Screw (w/Spring Washer/Plain Washer) 460V-60Hz(USA)	2	M4x16	SWRM	

PARTS LIST		AUTOMATIC DEWATERING PUMP			6/7/2018	
ITEM	PART No.	DESCRIPTION	QTY	SIZE	MATERIAL	NOTES
36	115-000-66	Transformer 208/220V-60Hz(USA)	1	EK200/20M		
	115-000-71	Transformer 460V-60Hz(USA)	1	EK460/20M		
	115-000-72	Transformer 575V-60Hz(USA)	1	EK525/20M		
37	143-169-17	Truss Screw	2	M3x8	SWRM	
38	143-183-17	Truss Screw	3	M3x20	SUS304	
39	114-000-90	Relay Unit	1	ME0K1-IA4		
40	143-085-21	Pan Screw (w/Spring Washer)	1	M4x6	SWRM	
41	143-126-12	Pan Screw (w/Spring Washer/Plain Washer)	2	M4x12	SWRM	
42	053-241-25	Motor Protector 208/220V-60Hz(USA)	1	KA313-GGXL110	(T.C)	
	053-000-02	Motor Protector 460V-60Hz(USA)	1	KA313-GDVL103	(T.C)	
	053-421-18	Motor Protector 575V-60Hz(USA)	1	KA313-GQXL102	(T.C)	
43	121-506-12	Packing (Water Way, Upp.)	1	KTZ23.7/33.7/43.7	NBR	*
44	050-001-04	Middle Bracket	1		FC	
45	140-427-17	Hex.Bolt (w/Plain Washer)	2	M5x15	SUS304	
46	090-000-43	Electrode Level Sensor	1Set	EK-4	CR	interchangable with OLD part# 090-000-40
	090-124-13	Probe Extension (OPTION)	1		SUS304	OPTIONAL ACCESSORY
47	142-196-10	Wave Washer	1	6205/6304	SK5	
48	052-107-12	Bearing	1	6304ZZC3		
49	122-367-12	O-Ring	1	52xd3.1	NBR	*
50	055-002-82	Rotor	1Set			
51	002-000-04	Cable Protection Tube	m	NFG-1A,d8	(Vm)	
52	147-026-13	Impeller Key	1	5x5x25L	SUS420	
53	002-000-19	Cable Protection Tube	1	NFG-1AC,d12		
54	181-072-10	Cable Tie	2	T18S,80Lx2.2Bx16D	Nylon	
55	056-001-27	Stator 208/220V-60Hz(USA)	1Set			
	056-001-29	Stator 460V-60Hz(USA)	1Set			
56	121-506-12	Packing (Water Way, Upp.)	1	KTZ23.7/33.7/43.7	NBR	*
57	122-276-13	O-Ring	1	160xd3.1	NBR	*
58	064-000-19	Motor Frame	1		FC	
59	140-078-19	Hex.Bolt	4	M10x35	SUS304	
60	142-164-19	Spring Washer	4	M10	SUS304	
61	121-247-12	Packing	1	d12.3xd18x2t	PE	*
62	140-000-17	Hex.Bolt (w/Flange)	1	M12x15(Oil Plug)	SUS304	
63	140-000-23	Hex.Bolt (w/Spring Washer)	4	M5x10	SWRM	
64	062-000-02	Bearing Cover	4	d5.5xd18x2t	SPC	
65	052-110-18	Bearing	1	6307ZZC3		
66	122-133-17	O-Ring	1	G-110(109.4xd3.1)	NBR	*
67	060-001-76	Bearing Housing	1		FC	
68	142-163-34	Spring Washer	4	M8	SWRH	

PARTS LIST		AUTOMATIC DEWATERING PUMP			6/7/2018	
ITEM	PART No.	DESCRIPTION	QTY	SIZE	MATERIAL	NOTES
69	140-054-48	Hex.Bolt	4	M8x20	SWRM	
70	025-001-00	Mechanical Seal	1	H-25T (RoHS)	SiC	supercedes 025-000-07
71	143-070-23	Pan Screw	2	M5x6	SWRM	
72	030-143-12	Oil Lifter	1	H-25(A)(T)	Resin	
73	143-070-10	Pan Screw	4	M5x6	SWRM	
74	030-148-17	Seal Stopper	1	HT-2530	SPCC	
75	122-283-13	O-Ring	1	165xd3.1	NBR	*
76	121-124-12	Packing (Water Way, Low.)	1	KTV-37/55	NBR	*
77	020-001-02	Pump Casing	1	KTZ23.7/33.7/43.7	FC	
78	026-144-49	Oil Seal	1	TC-40588	NBR	
79	040-106-27	Impeller Shim		d20.2xd30x0.3t	SUS304	
80	021-L17-18	Impeller (60Hz)	1	KTZE33.7-61	HiCrFC	
81	047-104-26	Impeller Thread Protect.Cover	1	No.3B(18)	SUS304	
82	142-166-11	Spring Washer	1	M16	SUS304	
83	141-033-15	Hex.Cap Nut	1	M16	SUS304	
84	120-109-21	Packing (S.Cover)		d180xd222x0.5t(d12)	PE	
85	022-000-55	Suction Cover	1	KTZ33.7/35.5	FCD	
86	142-128-24	Plain Washer	3	M10	SPC	
87	140-074-15	Hex.Bolt	3	M10x20	SUS304	
88	142-128-24	Plain Washer	3	M10	SPC	
89	144-000-31	Stud Bolt	3	M10x94(20/14)	SUS410	
90	023-471-10	Strainer Stand	1	KTZ23.7/45.5	SPCC	
91	142-128-24	Plain Washer	3	M10	SPC	
92	141-006-77	Hex.Nut	3	M10	S45C	
	173-003-37	Packing O-Ring Set	1Set	(Marked by *)		
12	122-121-12	O-Ring (S.Box)	1	G-50(49.4xd3.1)	NBR	*
21	121-001-48	Packing (Hose Coupling)	1	KTZ-3.7/7.5(Angle)	NBR	*
26	122-276-13	O-Ring (M.Head Cover/Middle Bracket)	1	160xd3.1	NBR	*
44	121-506-12	Packing (Water Way, Upp.)	1	KTZ23.7/33.7/43.7	NBR	*
50	122-367-12	O-Ring (Upp. Bearing)	1	52xd3.1	NBR	*
56	121-506-12	Packing (Water Way, Mid.)	1	KTZ23.7/33.7/43.7	NBR	*
57	122-276-13	O-Ring (Middle Bracket/M.Frame)	1	160xd3.1	NBR	*
61	121-247-12	Packing (Oil Plug)	1	d12.3xd18x2t	PE	*
66	122-133-17	O-Ring (M.Frame/Brg.Housing)	1	G-110(109.4xd3.1)	NBR	*
75	122-283-13	O-Ring (M.Frame/P.Casing)	1	165xd3.1	NBR	*
76	121-124-12	Packing (Water Way, Low.)	1	KTV-37/55	NBR	*
		Lubricant		Turbine Oil VG32 1,250ml		

PARTS LIST		AUTOMATIC DEWATERING PUMP			6/7/2018	
ITEM	PART No.	DESCRIPTION	QTY	SIZE	MATERIAL	NOTES

EXPLODED VIEW

KTZE33.7-61

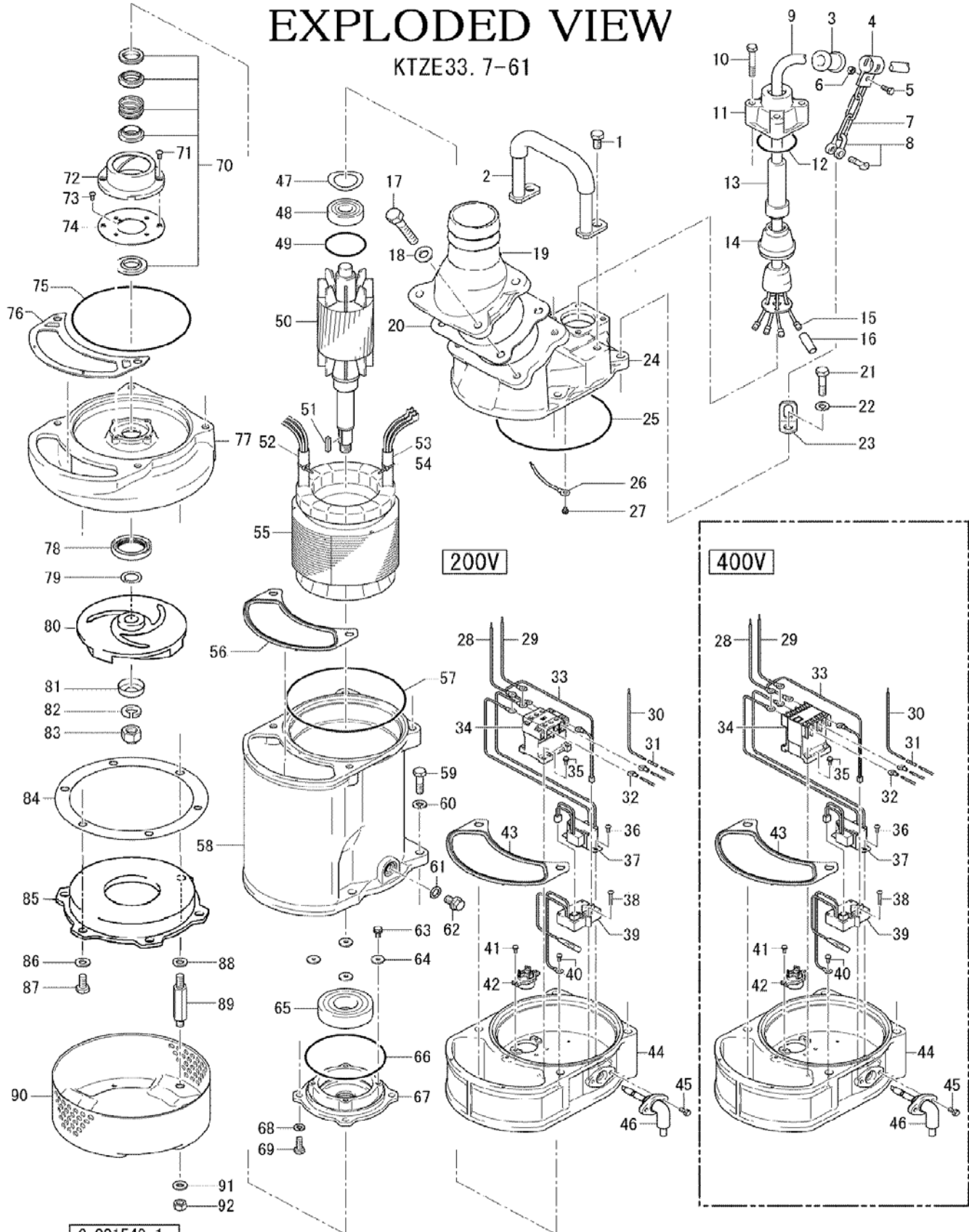

C-001549-1

* Indicates items included in set